

Internal Gear Pump

Series QYEH

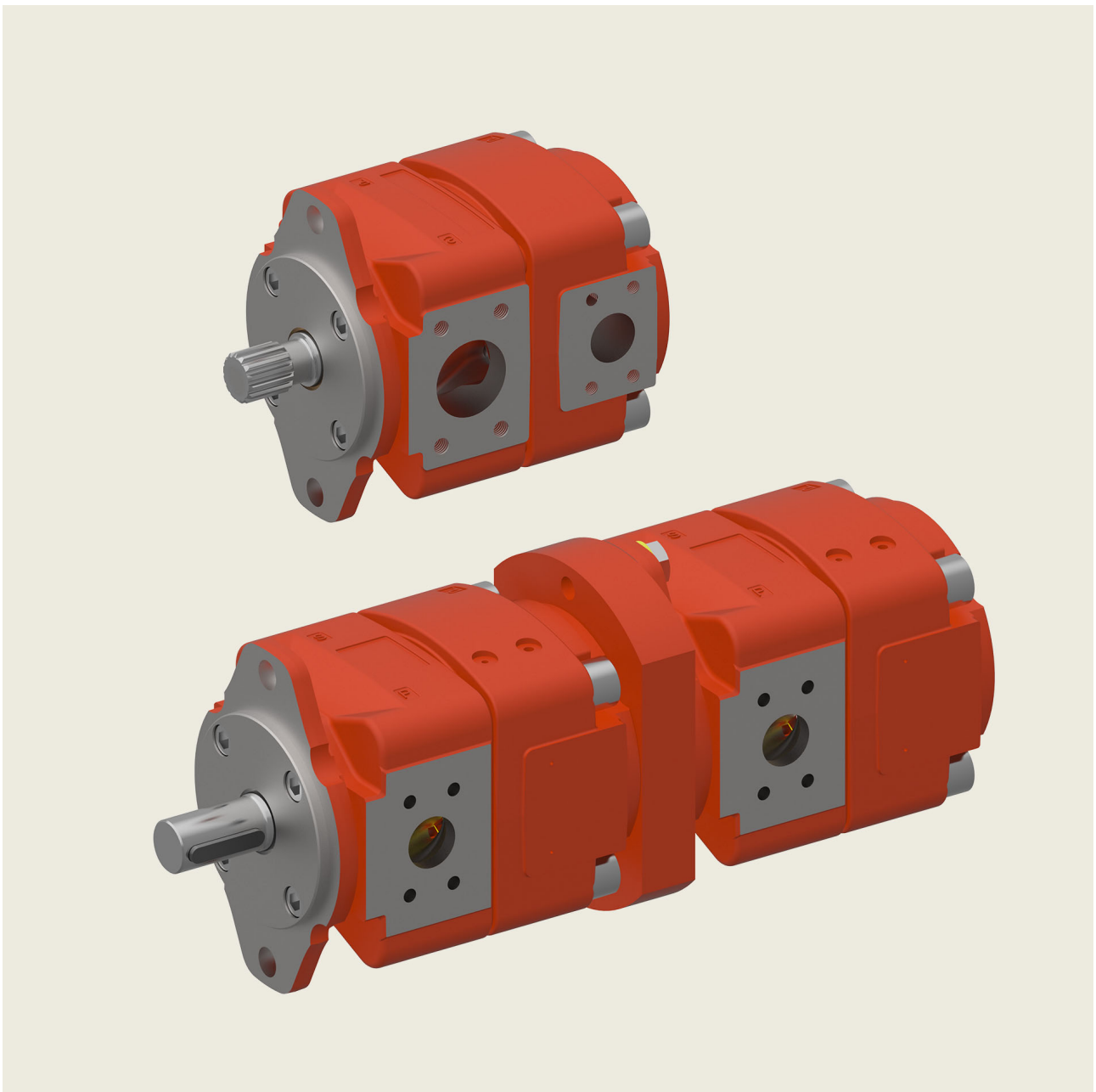

Contents		Page
1	General	5
	1.1 Product description	5
	1.2 Advantages	5
	1.3 Application examples	5
2	Technical data	5
	2.1 General	5
	2.2 Main characteristics	6
3	Performance graphs	7
	3.1 Noise level (Lp)	7
	3.2 Efficiencies (η)	7
	3.3 Operation with variable-speed drives	8
4	Single pumps	9
	4.1 Dimensions	9
	4.2 Ordering code	10
5	Double pumps	11
	5.1 Selection table	11
	5.2 Dimensions	12
	5.3 Ordering code	15
6	Fluid	16
7	Operational reliability	16
8	Note	16

1 General

1.1 Product description

The design of the internal gear pumps, series QYEH, is completely focused on high customer benefits. The pumps are ideal for use with variable speed drives over a very wide speed range and for operation in reverse mode. They work with just one gear stage, and thanks to their compact design they can be incorporated in machines in a particularly space-saving manner. The QYEH range displays further advantages in difficult environments with high cyclic loading: the rugged design provides high reliability throughout the long service life and enables the pumps to be used with various pressure media, because even with critical fluids they resist cavitation.

The minimised number of moving parts and the special tooth geometry ensure maximum acceleration values. This shortens the cycle time, which raises the productivity of the machine. Compared to other drives, including gap-compensated internal gear pumps, the QYEH range offers distinct advantages in this area.



1.2 Advantages

- Generates high pressures in just one stage
- Simple and compact construction
- Resists cavitation with critical fluids
- Very low noise levels
- Maximum reliability, also for reverse mode
- Pressure and flow pulsations are minimal
- Ideally suited for use with variable-speed drives

1.3 Application examples

- Hydraulic presses
- Injection moulding machines
- Machine tools
- Waste compactors
- Lift/elevator drives
- Pressure diecasting machines
- Plastics-processing machines
- Hydraulic power units

2 Technical data

2.1 General

Deviating values are possible on request.

General characteristics	Unit	Description, value
Installation attitude		unrestricted
Mounting method (standard)		oval 2-hole flange to ISO 3019/1 (SAE): QYEH 3-6
Direction of rotation		cw and ccw
Reverse mode		for pressure control / pressure relief, concerning the application limits please contact Bucher Hydraulics
Pump drive method		in-line, through a flexible coupling or direct connection with SAE tooth spline
Fluids		HLP mineral oils to DIN 51524, Part 2 HFC fluids to VDMA 24317
Maximum admissible level of contamination of the hydraulic fluid		ISO 4406 code 20/18/15
Operating viscosity	mm ² /s	10 ... 100
Start-up viscosity		10 ... 300

Hydraulic fluid temperature range	° C	HLP-mineral oils: -20 min. ... +80 max. HFC: -20 min. ... +50 max. range for max. long life cycle: +30 ... +60 (considering viscosity field)
Inlet pressure: suction port	bar	max 1.5 absolute (without external drain connection) min 0.5 ... 0.98 absolute (dependent on displacement and speed). option 06 (external drain port): inlet pressure up to 100 bar
Start-up under load	bar	max. 20
Seal material		NBR (Nitrile) = standard, FPM (Viton) = option

2.2 Main characteristics

IMPORTANT: The main characteristics are valid for mineral oils DIN 51524 with a viscosity of 20 ... 50 mm²/s.

Displacement ¹⁾ effective	Flow rate 1450 rpm p = 0 bar	Maximum speed ⁵⁾		Code	Max. operating pressure at the pump outlet side				Torque ³⁾ [Nm]	Power consumption ⁴⁾ [kW]
		Mineral oil	HFC		Mineral oil	HFC	Mineral oil	HFC		
		[cm ³ /rev]	[l/min]		[rpm]	[rpm]	[bar]	[bar]		
10, 0	14, 5	5500	5000	QYEH32-010	250	220	280	240	39, 8	6, 0
12, 6	18, 3	5100	4500	QYEH32-012	250	220	280	240	50, 1	7, 6
15, 6	22, 6	4300	3800	QYEH32-016	250	220	280	240	62, 1	9, 4
20, 3	29, 5	4000	3600	QYEH42-020	250	220	280	240	80, 8	12, 3
25, 1	36, 4	3700	3200	QYEH42-025	250	220	280	240	99, 9	15, 2
32, 3	46, 8	3400	2800	QYEH42-032	250	220	280	240	128, 5	19, 5
39, 1	56, 9	3200	2700	QYEH52-040	250	220	280	240	155, 6	23, 6
50, 3	73, 2	3000	2600	QYEH52-050	250	220	280	240	200, 1	30, 4
63, 4	92, 1	2800	2400	QYEH52-063	250	220	280	240	252, 3	38, 3
79, 8	116	2700	2300	QYEH62-080	250	220	280	240	317, 5	48, 2
100, 5	146	2500	2200	QYEH62-100	250	220	280	240	399, 9	60, 7
124, 2	181	2300	2000	QYEH62-125	250	220	280	240	494, 2	75, 0

1) Due to manufacturing tolerances, there may be slight variations in the displacement.

2) Maximum 20 seconds, but not for more than 40% of the duty cycle.

3) Theoretical value without taking into account the efficiencies at the maximum permissible continuous pressure for mineral oil at the pump outlet.

4) Theoretical value without taking into account the efficiencies at the maximum permissible continuous pressure for mineral oil at the pump outlet at n = 1450 rpm.

5) Maximum rated speeds for inlet pressure > 0.95 bar (abs.) and outlet pressure > 100 bar. For operation with higher speed contact Bucher Hydraulics.

3 Performance graphs

IMPORTANT: The performance graphs shown are valid for the specified pump models. For other pump models contact Bucher Hydraulics GmbH.

3.1 Noise level (L_p)

Measured to DIN 45635, Part 26, in Stuttgart University's low-echo noise measurement chamber:
measurement distance 1 m
speed $n = 1500$ rpm, viscosity = 42 mm²/s

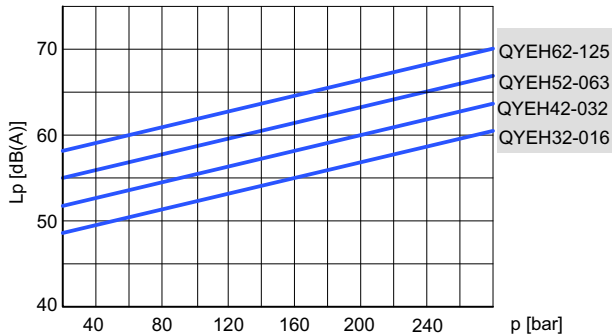

3.2 Efficiencies (η)

Measured at viscosity 42 mm²/s, speed 1450 rpm.

3.2.1 QYEH32

Volumetric efficiency

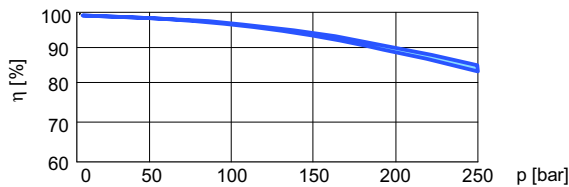

Hydromechanical efficiency

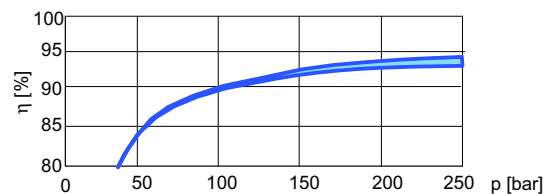

3.2.2 QYEH42

Volumetric efficiency

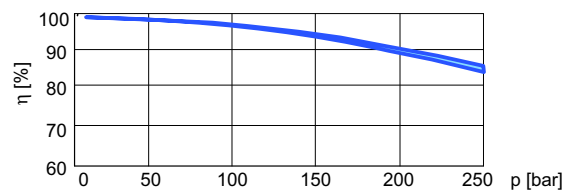

Hydromechanical efficiency

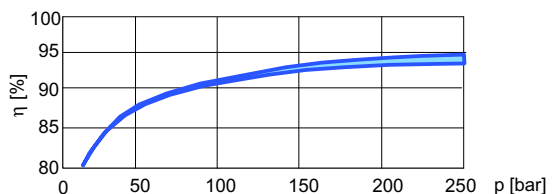

3.2.3 QYEH52

Volumetric efficiency

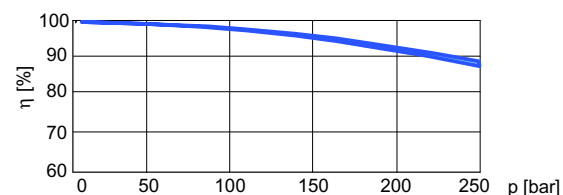

Hydromechanical efficiency

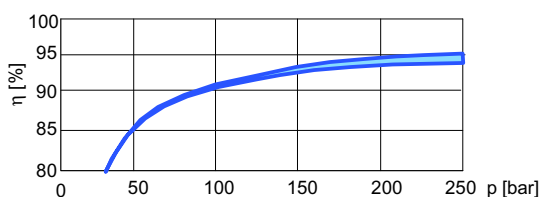

3.2.4 QYEH62

Volumetric efficiency

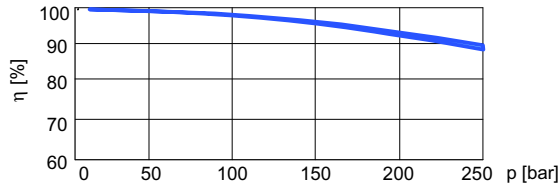

Hydromechanical efficiency

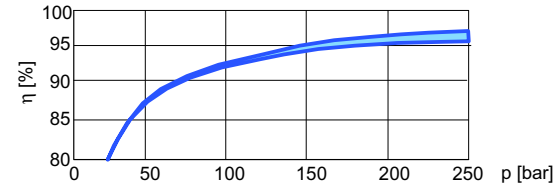

3.3 Operation with variable-speed drives

IMPORTANT: The following main characteristics are to be understood as examples only. They are valid only for QYEH52-063R06 with a viscosity of 42 mm²/s. We would be very happy to advise you on the layout of your drive. All QYEH pumps with variable-speed drive contain an external drain port (option 06).

3.3.1 Loading example for use in injection moulding machines

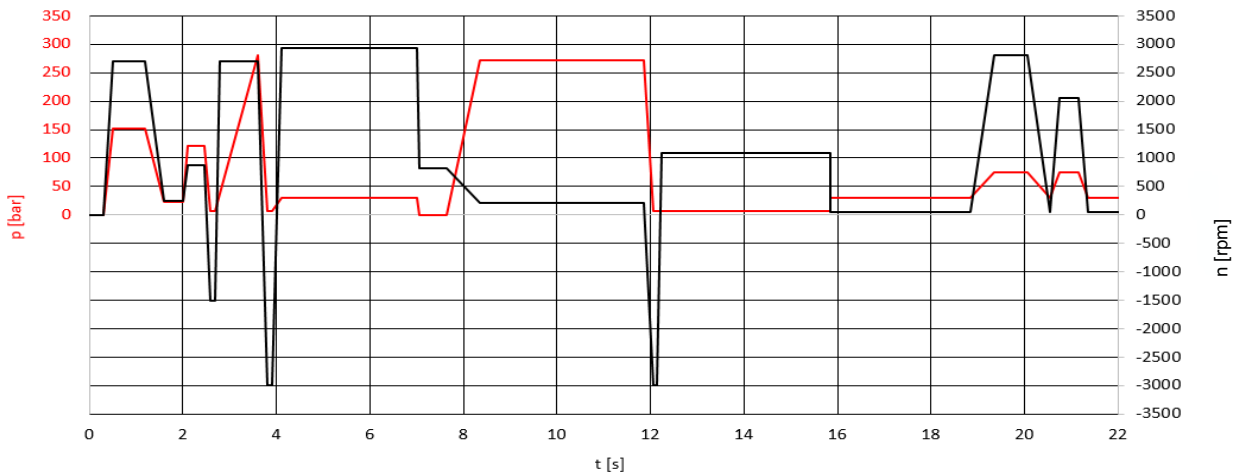

3.3.2 Minimum pressure (absolut) at pump inlet as a function of speed

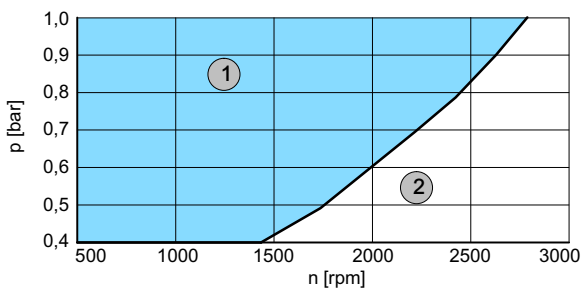

1	continuous operation
2	no operation

3.3.3 Minimum speed as a function of pressure

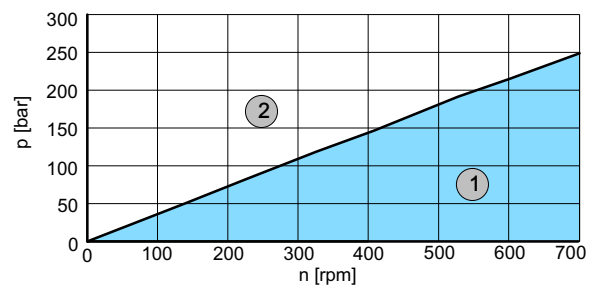

1	continuous operation
2	Operation with time restrictions. Detailed operating limits after discussion with Bucher Hydraulics.

4 Single pumps

4.1 Dimensions

Frame size		3	4	5	6
Suction port	S	G1¼" ³⁾ thread	1½" ¹⁾	2" ¹⁾	2½" ¹⁾
Pressure port	P	G¾" ³⁾ thread	1" ¹⁾	1¼" ¹⁾	1½" ¹⁾
External drain port (option)	①	G¼"	G¼"	G¼"	G¾"
Mounting method: oval 2-hole flange to ISO 3019/1 (SAE) ISO 3019/2 (Metr.)	A	132	170	212	267
	B (SAE)	106	146	181	229
	B (Metr.)	-	-	-	-
	C	11	14	18	22
	N (SAE)	82,55 - 0,05	101,6 - 0,05	127 - 0,05	152,4 - 0,05
	N (Metr.)	-	-	-	-
	O	8,5	10,5	12,5	16,5
Shaft end: parallel, to ISO/R775 ²⁾	D	20 j6	25 j6	32 j6	40 j6
	E	36	42	58	82
	F	6	8	10	12
	G	22,5	28	35	43
	I	44	51	68	92
Body	K	44	52,5	60,5	74
	L	142,5	176	210	249
	T1	114	137	177	220
	T2	54	67	88,5	110
	Z	60	62,5	78	98,5
Weight	kg	9,5	17	31	60

1) Pipe flange dimensions, SAE J518 code 61 bzw. ISO 6162-1
 - high-pressure type for up to 420 bar (see section 9.1)
 - low-pressure type for up to 16 bar (see section 9.2)

2) For other shaft ends please consult Bucher Hydraulics.

3) Threaded port to DIN 3852, Part 2.

4.1.1 Frame size 3

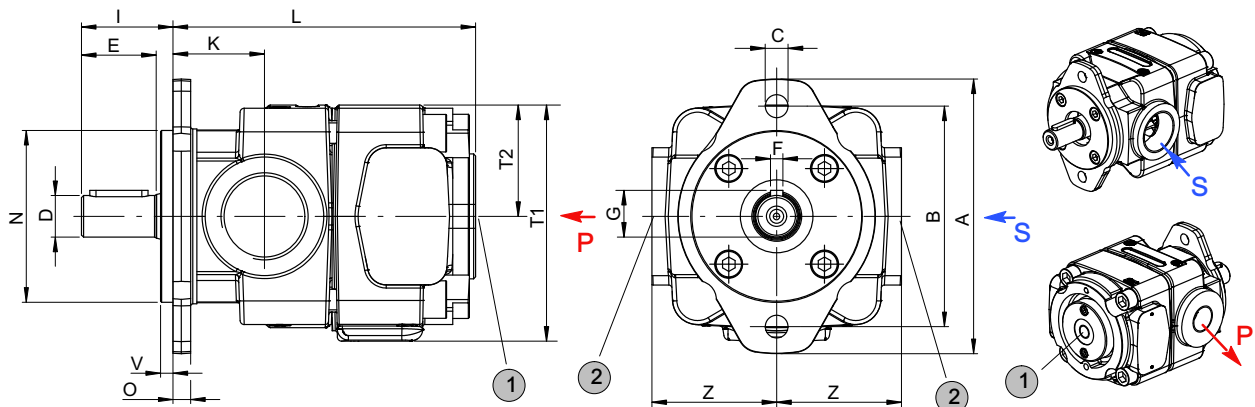

1	external drain port on models with option 06	2	threaded port to DIN 3852 Part 2
---	--	---	----------------------------------

4.1.2 Frame size 4 - 6

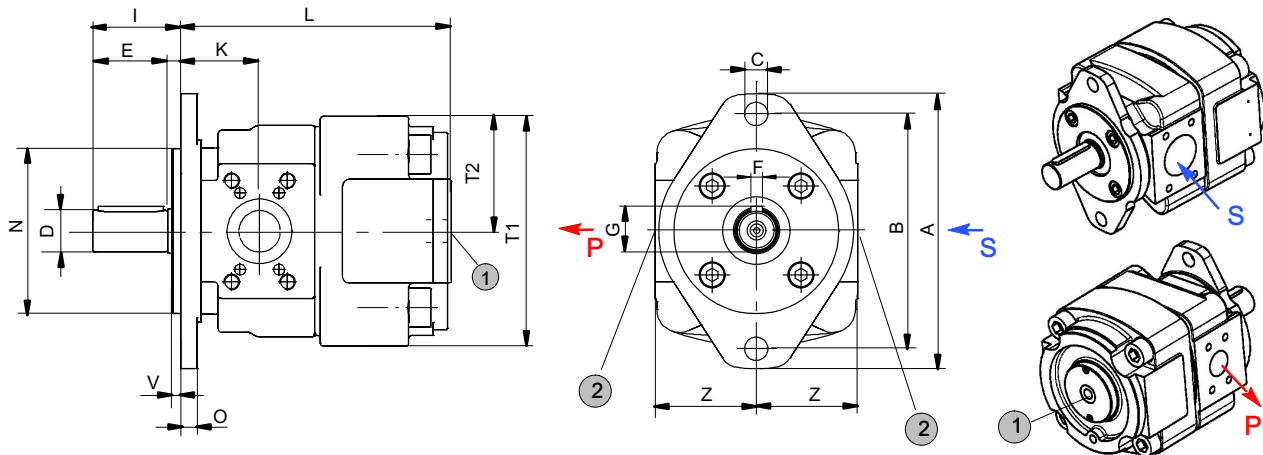

1	external drain port on models with option 06	2	threaded port to DIN 3852 Part 2
---	--	---	----------------------------------

4.2 Ordering code

		Q Y E H	5 2	-	0 4 0	R	0 9
Series	=	QYEH					
Frame size	=	32, 42, 52, 62					
Displacement in cm ³ /rev	=	010 - 124,2					
Direction of rotation (viewed from the shaft end)							
right / cw (standard)	=	R					
left / ccw	=	L					
Option		see section 4.2.3					

4.2.1 Ordering example:

Required: single pump
 Displacement: 40 cm³/rev
 Continuous pressure: 250 bar

Seal material: FPM (Viton)
 For use with mineral oil

Ordering Code: QYEH52-040R09

4.2.2 Standard configuration

- direction of rotation - right (cw)
- 2-hole mounting flange to ISO 3019/1 (SAE): sizes QYEH 3-6
- Nitrile seals
- cylindrical shaft end to ISO R775
- black priming RAL 9004, flange without priming

4.2.3 Options

- O = pump without priming
- 06 = external drain port
 QYEH 3-5 = G¹/₄"
 QYEH 6 = G³/₈"
- 09 = seal material FPM (Viton), without priming
- 11 = shaft end with spline shaft
 SAE ANSI B92.1, DIN ISO 3019-1
- 11-6 = combination of option 11 and 06
- 29 = for HFB and HFC fluids,
 pump without priming
- 29-6 = combination of option 29 and option 06

5 Double pumps

QYEH pumps of the same size or of different sizes can be combined to form double pumps.

This double pump consists of two hydraulically separated single pumps driven by one motor unit.

An internal coupling connects the two pinion shafts, both of which are a one-piece design. The two single pumps each have a suction and a pressure port.

The larger pump of a combination is located on the shaft-end side (the drive side) and is referred to as pump 1. Where both pumps have the same frame size, the pump with the larger displacement is on the drive side. Combinations are available with the same frame size and with the next-larger/smaller size (see Section 5.1). The relevant dimension pages for the combinations can be found in Section 5.2.

5.1 Selection table

		Pump 2												
		Size												
		QYEH32			QYEH42			QYEH52			QYEH62			
		Displacement [cm ³ /rev]												
		10	12	16	20	25	32	40	50	63	80	100	125	
Pump 1	Maximum admissible torque [Nm] at the drive end	190 Nm	QYEH32	10	X									
			12	X	X									
			16	X	X	X								
	350 Nm		20	X	X	X	X							
			25	X	X	X	X	X						
			32	X	X	X	X	X	X					
	750 Nm		40				X	X	X	X				
			50				X	X	X	X	X			
			63				X	X	X	X	X	X		
	1370 Nm		80							X	X	X	X	
			100							X	X	X	X	X
			125							X	X	X	X	X

5.2 Dimensions

5.2.1 QYEH32-...//32-...

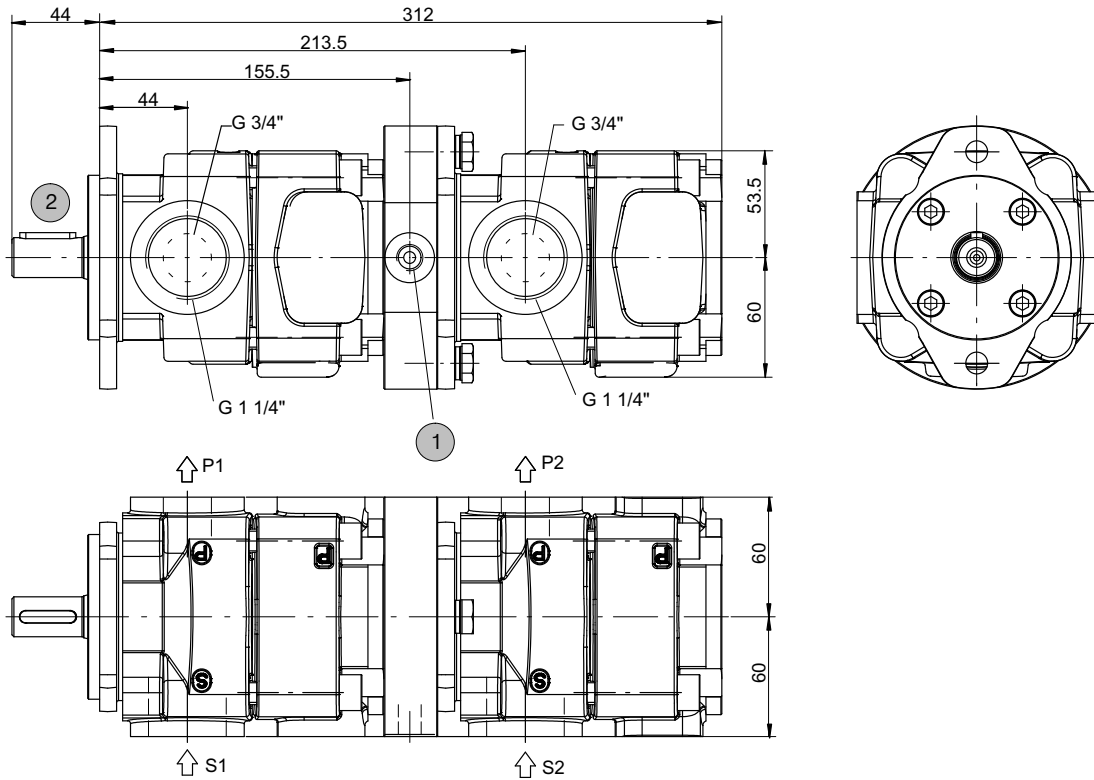

5.2.2 QYEH42-...//32-...

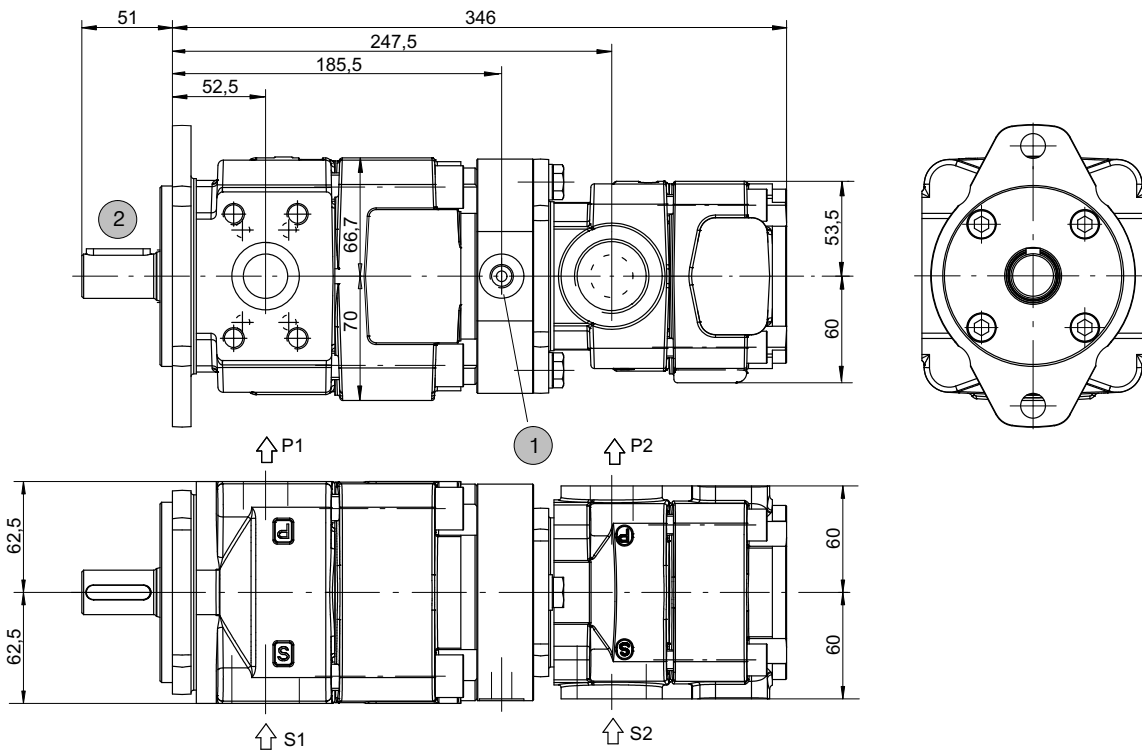

1	external drain port G 3/4"	2	shaft and mounting dimensions see section 4
---	----------------------------	---	---

5. 2. 4 QYEH52-...//42-...
QYEH62-...//52-...

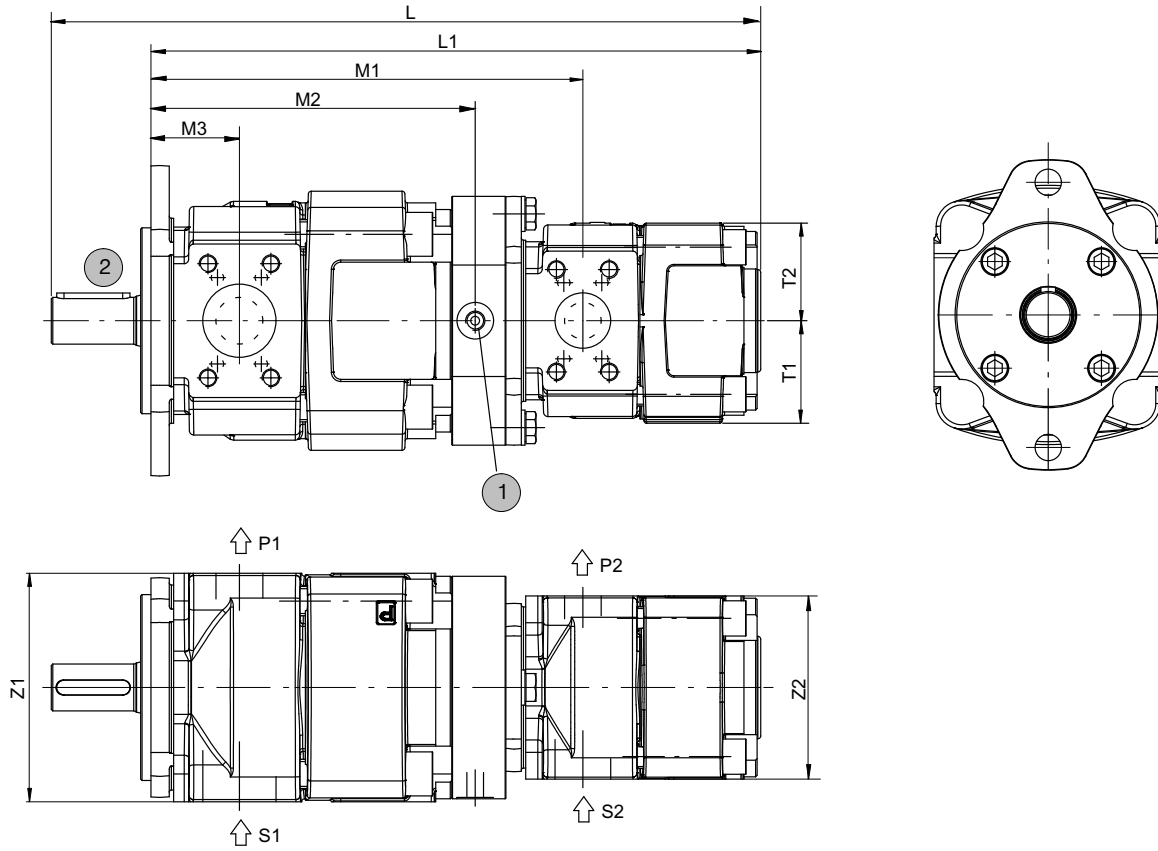

1 external drain port						2 shaft and mounting dimensions see section 4							
Type	L	L1	M1	M2	M3	T1	T2	Z1	Z2	S1	S2	P1	P2
QYEH52//42	484,5	416,5	295	221,5	60,5	70	66,7	156	125	SAE 2 “	SAE 1½ “	SAE 1¼ “	SAE 1 “
QYEH62//52	586	494	346	266	74	110	110	197	156	SAE 2½ “	SAE 2 “	SAE 1½ “	SAE 1¼ “

6 Fluid

QYEH pumps require fluid with a minimum cleanliness level of ISO 4406 code 20/18/15.

We recommend the use of fluids that contain anti-wear additives for operation with boundary lubrication. Fluids without appropriate additives reduce the service life of pumps and motors. The user is responsible for maintaining, and regularly checking the fluid quality. Bucher Hydraulics recommends a load capacity of $\geq 30 \text{ N/mm}^2$ to Bruggen DIN 51347. This is particularly important in applications with variable-speed drives and speeds $< 1000 \text{ rpm}$.

7 Operational reliability

To guarantee the reliable operation and a long service life of the QYEH, a maintenance schedule must be prepared for the power unit, machine or system. The maintenance schedule must make sure that the provided or permissible operating conditions of the pump are adhered to over the period of use.

In particular, compliance with the following operating parameters must be ensured:

- the required oil cleanliness
- the operating temperature range
- the fluid level

Moreover, the pump and the system must be inspected at regular intervals for changes in the following parameters:

- vibration
- noise
- differential temperature of pump – fluid in the tank
- foaming in the tank
- freedom from leakage

Changes in these parameters indicate wear of components (e.g. drive motor, coupling, pump, etc.). The cause must be immediately pinpointed and eliminated.

To provide high operational reliability of the QYEH in the machine or system, we recommend continuous, automatic checks of the above parameters and an automatic shut-down in the case of changes that exceed the usual fluctuations within the provided operating range.

8 Note

This catalogue is intended for users with specialist knowledge. The user must check the suitability of the equipment described herein in order to ensure that all of the conditions necessary for the safety and proper functioning of the system are fulfilled. If you have any doubts or questions concerning the use of these pumps, please consult Bucher Hydraulics.